

STEELCOAT 700™ SYSTEM*



A two-part glass flake reinforced epoxy mastic coating system for the protection of above ground steelwork

The Steelcoat 700™ System comprises a minimum of two coats of Premier S.T. Epoxy™ (the epoxy mastic coating) which is easily applied by brush or airless spray. Premier S.T. Filler™ is utilised to fill any voids, gaps or bad pits.

The Steelcoat 700™ System is used wherever steel grit blasting is not possible. It is ideal for applications such as structural steel, pipe externals, pipe racks, tanks, offshore platforms, locks, gates, and bridges.

When exposed to ultraviolet light a third coat of Urethane based material (Archco 65™ Topcoat) is applied for extra protection (prevents chalking). Light colours of Premier S.T. Epoxy™ are recommended to ensure the epoxy is fully covered with the final Archco 65™ Topcoat for optimum ultraviolet protection.

FEATURES

- Provides long term exterior protection
- Excellent water/sea water resistance
- Good resistance to acids and alkalis
- Good flexibility, hardness and adhesion
- Good impact resistance
- Low VOC

COMPONENTS

Premier S.T. Epoxy™

Options:

Premier S.T. Filler™

Archco 65™ Topcoat

For optimum ultraviolet protection.

SURFACE PREPARATION

Minimal surface preparation required. Surfaces must be clean and dry. Remove all loose rust, scale and flaking coatings by hand or power tool to St2/St3 (ISO 8501-1).

*Steelcoat 700 is not available for sale in the UK or EU.

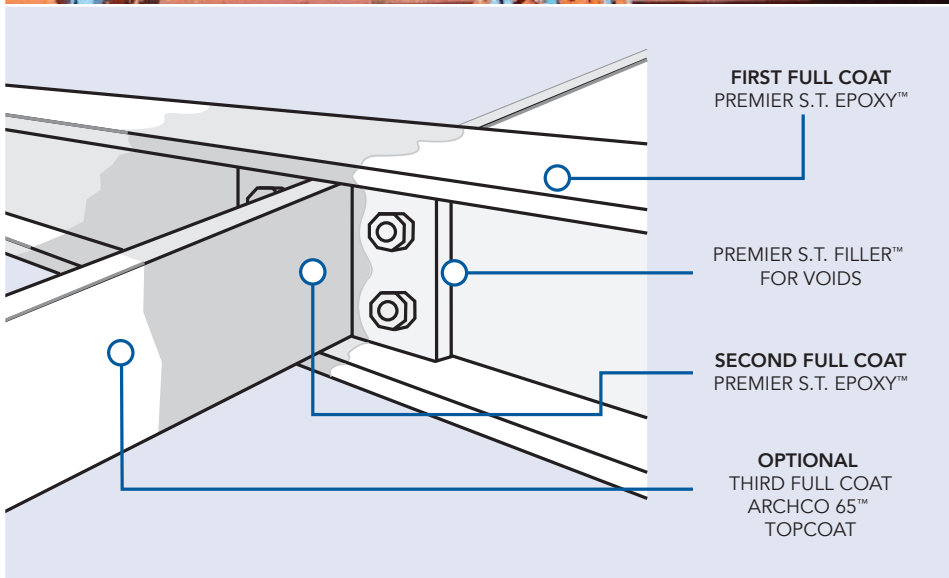

PUB No. 514.08.2020

PREMIER COATINGS LIMITED

TEL: +44 (0) 1233 770 663

FAX: +44 (0) 1233 770 633

EMAIL: enquiries@premiercoatings.com

WEB: www.premiercoatings.com

Marley Farm, Headcorn Rd

Smarden, Ashford

TN27 8PJ

UNITED KINGDOM



THE QUEEN'S AWARDS
FOR ENTERPRISE
INTERNATIONAL TRADE
2017



Q 09303 | EMS 677780
ISO 9001:2015 & ISO 14001:2015



UKAS
MANAGEMENT
SYSTEMS
0003



A MEMBER OF WINN & COALES INTERNATIONAL