

INSTRUCTIONS FOR USE

PremcoteTM Tapes for the long-term protection of buried or immersed pipes, welded joints, bends, fittings and similar structures from corrosion.

To protect the metal structure from the environment the tape must cover the entire surface.

EQUIPMENT

- Hand wire brush / power tool / blast cleaning equipment (optional).
- Brush, brush cleaning solvent.
- Utility knife and Holiday Detector (optional).
- PPE must be worn in accordance with the manufacturer's recommendations as set out in the Safety Data Sheets.

SURFACE PREPARATION

Surfaces must be clean, dry and free from grease. Remove all loose rust, scale and flaking coatings by wire brushing to ISO 8501-1 St 3 or abrasive blast clean to ISO 8501-1 Sa 2½.

APPLICATION PROCEDURE

Diagram of correct application procedure:

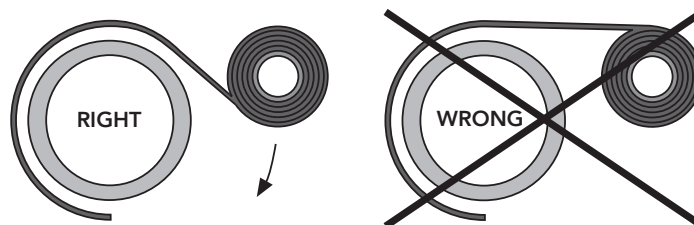

1. PRIMING

Brush apply one coat of PremcoteTM Primer over the entire area to be wrapped. Allow to dry for 20 minutes or until touch dry.

Coverage:	9-11m ² /l
Wet film thickness:	90-110 microns
Dry film thickness:	40-50 microns
Drying time:	Approx. 20 minutes

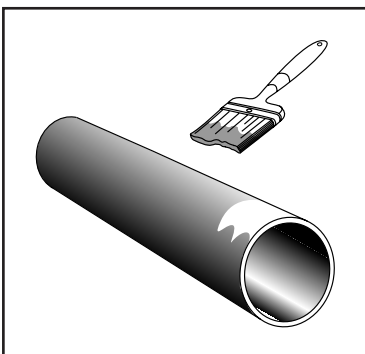

Fig. 1: Priming pipes, rods and cables. Apply Premcote Primer to entire area to be wrapped with tape.

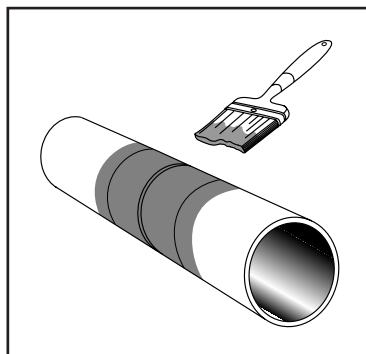

Fig. 2: Priming butt welded joints. Apply Premcote Primer to entire area to be wrapped with tape.

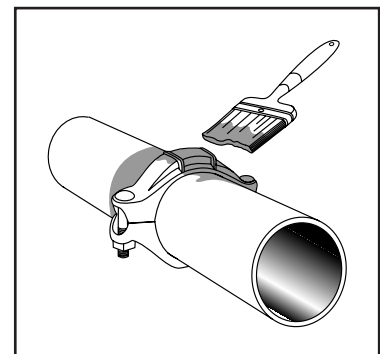

Fig. 3: Priming flanges and couplings. Apply Premcote Primer to entire area to be wrapped with tape.

PREMCOTE 150™, PREMCOTE 500™, PREMCOTE 1500™ (TEMPERATE), PREMCOTE 1550™, PREMCOTE 150™ TROPICAL, PREMCOTE™ 101 TROPICAL, PREMCOTE 500™ TROPICAL, PREMCOTE 1000™ TROPICAL & PREMCOTE 1500™ TROPICAL

2. APPLICATION

A) PIPES, RODS AND CABLES

Select as wide a width of tape as practical, e.g. 100mm wide for 150mm diameter pipe. Peel back about 0.5m of interleaving and apply the adhesive side of the tape firmly to the pipe. Unroll the tape about 0.5m, peel back the interleaving and wrap the tape spirally ensuring correct alignment. Maintain sufficient tension to ensure that the tape conforms to the surface without gaps. Repeat this, overlapping each turn by 55% to give double thickness. Start a new roll by overlapping the ends by one tape width.

NOTE: Where longitudinal welds are included in the area to be wrapped, apply a 100mm wide strip of the tape longitudinally over the weld and press into the contours before wrapping.

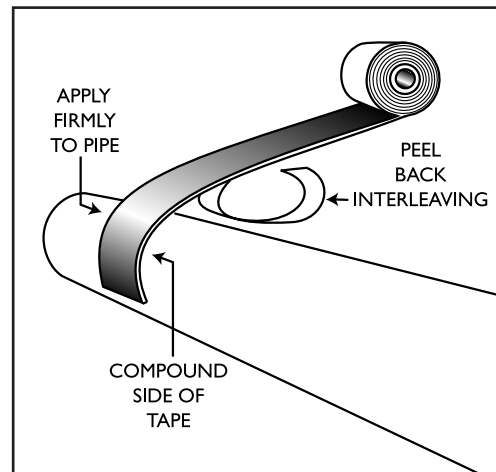

Fig. 4: Starting the first roll of tape.

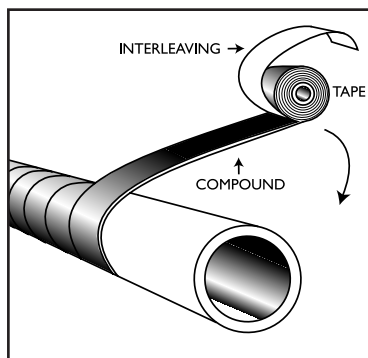

Fig. 5: Diagram showing the correct application procedure for wrapping tape.

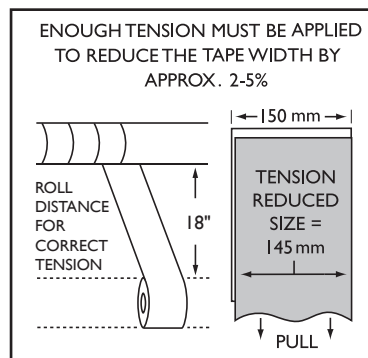

Fig. 6: Ensure that tape is applied with the correct amount of tension to reduce width as shown in illustration above.

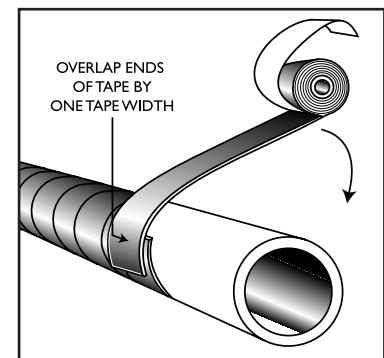

Fig. 7: Starting a new roll of tape.

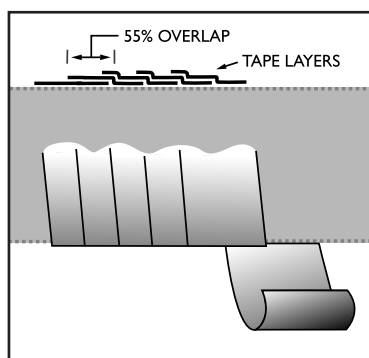

Fig. 8: Overlapping each turn by 55% gives a double thickness.

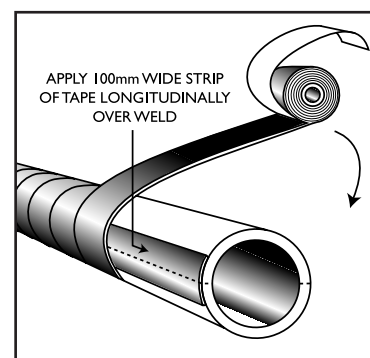

Fig. 9: Wrapping a longitudinal weld.

B) BUTT WELDED JOINTS

Finish as **(A)** but start and finish wrapping with a minimum of 75mm overlap on to the existing pipe coating either side of the joint area.

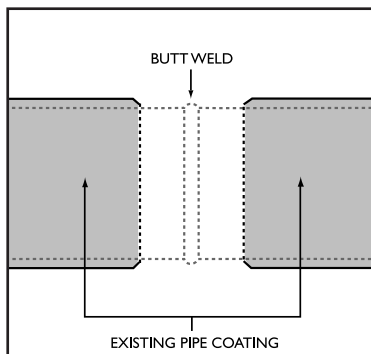

Fig. 10: Butt weld and existing coating ready for overwrapping with tape. Note cutback of coating can be 75mm - 150mm either side of the weld except on FBE coated pipe.

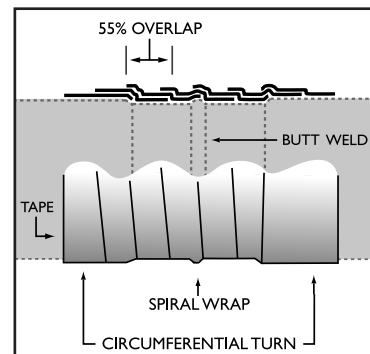

Fig. 11: Note method of wrapping.
 1. Start with one circumferential turn onto factory coating.
 2. Then change to spiral wrap with 55% overlap over weld area.
 3. Finish with one circumferential turn over factory coating the opposite side of the weld. Overlap tape at least 75mm onto existing coating.

C) FLANGES, COUPLINGS AND VALVES

Profile the pipe joint with Premier™ Moulding Compound or Premier™ LD Mastic so that there will be no air gaps under the subsequent tape wrapping. Push the mastic firmly into all cavities and around all bolt heads, building it up to form a smooth profile suitable for wrapping – without forming bridges or voids.

Start the tape on the centre of the crown of the joint and wrap away from the centre, towards the adjoining pipe, overlapping each turn by 55% to give double thickness. Select a narrow width tape for this. Finish with at least one circumferential wrap onto the pipe to conclude first half of the application.

On the crown of the joint, start a new roll by overlapping the ends of tape by one tape width. Wrap towards the pipe on the opposite side of the joint, overlapping the tape by 55%. Smooth finished wrap down well – particularly at the tape edges.

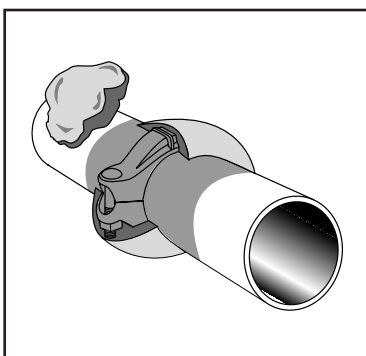

Fig. 12: Profiling the joint.

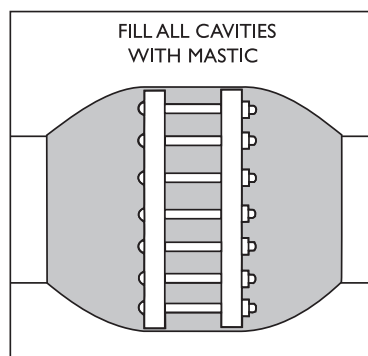

Fig. 13: Make sure that the mastic is pushed into all crevices and that it forms a smooth profile for wrapping.

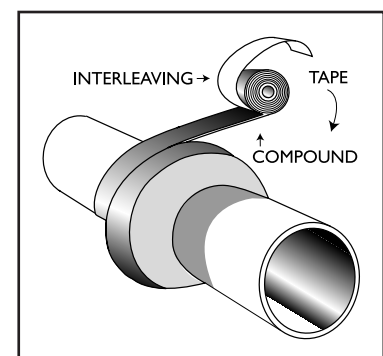

Fig. 14: Wrap joint in two halves. Start on crown and work towards pipe, then repeat from crown working towards pipe on opposite side of joint.

PREMCOTE 150™, PREMCOTE 500™, PREMCOTE 1500™ (TEMPERATE), PREMCOTE 1550™, PREMCOTE 150™ TROPICAL, PREMCOTE 101™ TROPICAL, PREMCOTE 500™ TROPICAL, PREMCOTE 1000™ TROPICAL & PREMCOTE 1500™ TROPICAL

D) DAMAGED COATINGS

Either cut a circumferential band of the damaged coating and treat as for Butt Welded Joints or cut away and remove loose coating from the damaged area and smooth or chamfer edges. Prime the exposed metal and a circumferential band extending 75mm either side of the damage. Build up the damaged area with patches of tape or Premier Moulding Compound. Wrap the section of pipe as for Butt Welded Joints.

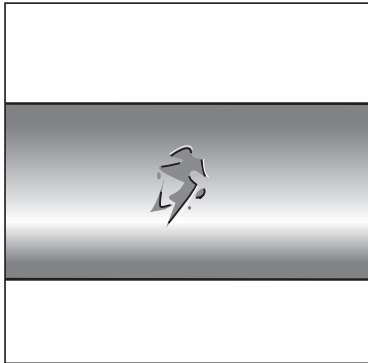

Fig. 15: Damaged pipe coating.

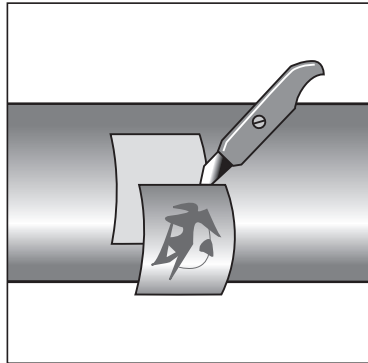

Fig. 16: Remove loose or damaged area then clean thoroughly.

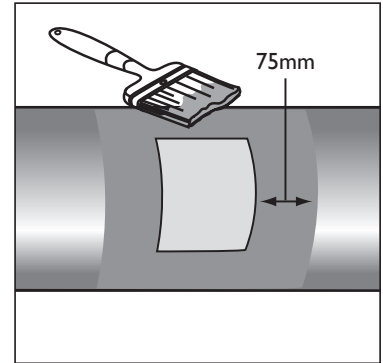

Fig. 17: Smooth edges and prime area at least 75mm onto sound coating.

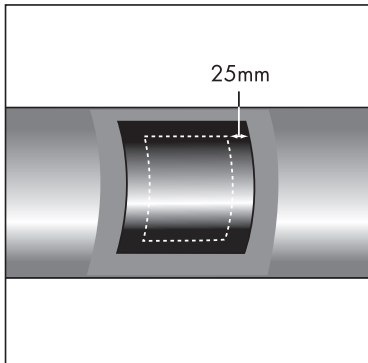

Fig. 18: Repair damaged area with a patch of tape overlapping at least 25mm onto primed sound coating area before wrapping with tape as (B).

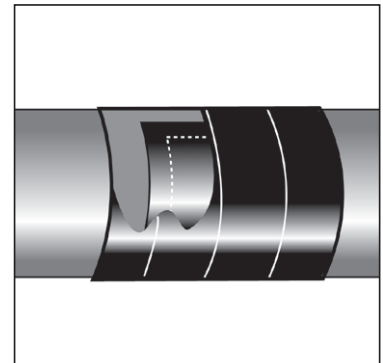

Fig. 19: Overwrap repair as (B).

3. INSPECTION

Ensure that the entire surface is covered with no gaps or air pockets. Examine adhesion by coupon test 24 hours after wrapping. Perform a holiday test using the correct voltages according to the tape and number of layers used (refer to the table on the following page).

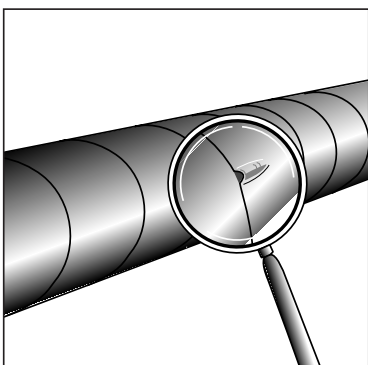

Fig. 20: Examine for gaps or air pockets (see repair procedure Figs. 15 to 19).

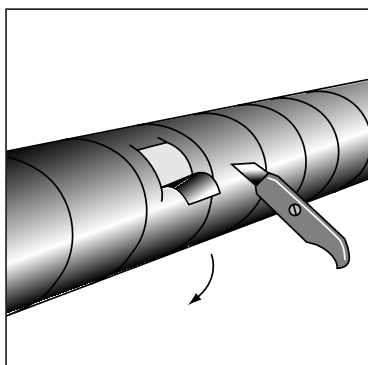

Fig. 21: Adhesion can be tested by pulling/removing a 50mm wide coupon of tape from the surface.

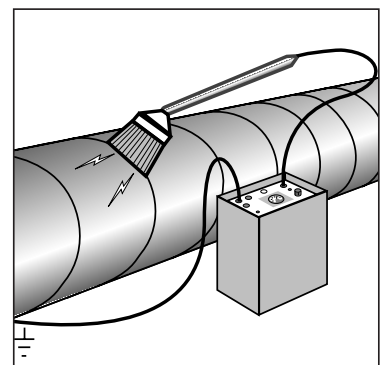

Fig. 22: Perform a holiday test using a ring or brass brush (refer to the table for holiday detection voltages).

PREMCOTE 150TM, PREMCOTE 500TM, PREMCOTE 1500TM (TEMPERATE), PREMCOTE 1550TM, PREMCOTE 150TM TROPICAL, PREMCOTE 101TM TROPICAL, PREMCOTE 500TM TROPICAL, PREMCOTE 1000TM TROPICAL & PREMCOTE 1500TM TROPICAL

APPLICATION TEMPERATURES & HOLIDAY DETECTION VOLTAGES

For ease of application, avoid using tape stored under very cold conditions.

		APPLICATION TEMPERATURE		HOLIDAY DETECTION VOLTAGE	
		MINIMUM	MAXIMUM	1 LAYER	2 LAYER
STANDARD	Premcote 150 TM	+5°C	+50°C	5 kV	15 kV
	Premcote 500 TM	+5°C	+45°C	10 kV	15 kV
	Premcote 1500 TM (Temperate)	+5°C	+45°C	10 kV	15 kV
	Premcote 1550 TM	+5°C	+45°C	10 kV	15 kV
TROPICAL	Premcote 150 TM Tropical	+15°C	+50°C	5 kV	15 kV
	Premcote 101 TM Tropical	+5°C	+50°C	10 kV	15 kV
	Premcote 500 TM Tropical	+15°C	+50°C	10 kV	15 kV
	Premcote 1000 TM Tropical	+15°C	+50°C	10 kV	15 kV
	Premcote 1500 TM Tropical	+18°C	+50°C	10 kV	15 kV

STORAGE

- Store correct way up in original packaging.
- Store away from heat and open flames.
- Do not store in direct sunlight.
- In cold conditions, tape may need to be warmed to comply with minimum application temperatures (see above).
- Standard Grades store between: +5°C and +20°C
- Tropical Grades store between: +5°C and +35°C

HANDLING

- Do not get in eyes, on skin, or on clothing.
- Wash thoroughly after use and before work breaks to remove compound from the skin.
- Careful attention should be given to personal hygiene.
- Change and clean soiled clothing.

Please refer to Safety Data Sheets for full information.

DISPOSAL

Please minimise or avoid waste wherever possible. Please do not discard waste material, including packaging, in the surrounding environment. Follow all relevant legislation for disposal.

IMPORTANT: Premier Coatings Ltd pursue a policy to develop and continually improve all of our products and therefore information given in this data sheet is intended as a general guide and does not constitute a warranty or specification. However, our sales personnel are committed to assisting the user in establishing the suitability of the product for its intended purpose and additional specific information is available on request. These Instructions may not cover all circumstances and must be read in conjunction with the project specifications. For further advice contact Premier Coatings Ltd.



PREMIER COATINGS LTD

Headcorn Road, Smarden, Ashford, Kent TN27 8PJ, United Kingdom
 TEL: +44 (0) 1233 770663 • EMAIL: enquiries@premiercoatings.com
 WEB: www.premiercoatings.com

