

INSTRUCTIONS FOR USE

USE

Premstrip™ is a flexible jointing compound supplied as a preformed strip for making joints between precast concrete units such as manholes, house inspection chambers, pipes, culverts, pedestrian subways, tunnels, shafts and segmental tanks.

SURFACE PREPARATION

Damaged joints must be properly repaired. Joint surfaces must be clean and dry. When damp, dry by use of gas torch. Brush to remove dust, dirt and loose material (**fig 1**).

PRIMING

Brush apply one coat of Premstrip™ Primer to each surface and allow to dry (**fig 2**). Primed surfaces which have been exposed and have become dull should be re-primed before use.

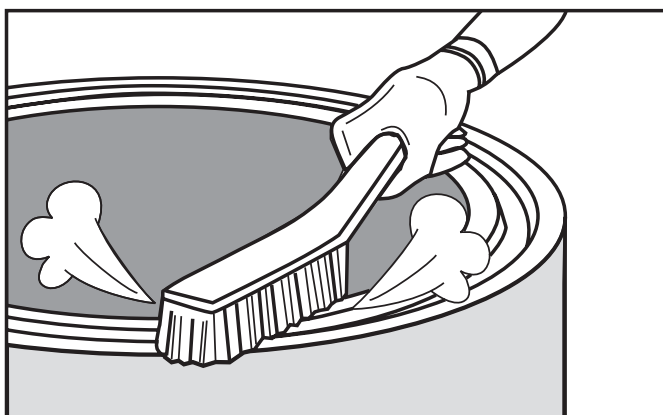

Fig 1. Joint surfaces should be sound, clean and dry before priming

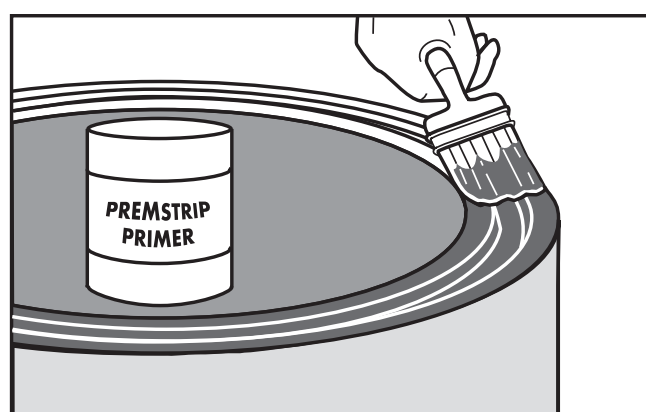

Fig 2. Prime both joint surfaces and allow to dry

PREMSTRIP APPLICATION PROCEDURE

(a) MANHOLE JOINTS

Joints compressed under weight of upper unit (e.g. manhole and house inspection chamber joints).

Select the recommended size of Premstrip™. Remove dirt or moisture from the primed surface. Position the Premstrip™ according to the type of joint as shown in **fig 7 A-G**. Apply the Premstrip™ as shown in **fig 3**, press into place and remove the interleaving.

Premstrip™ must be positioned all around the joint with no gaps. To join Premstrip™, taper the ends by cutting through with a hot knife to provide a 45° bevel, pressing the ends together and smoothing with a hot knife (**fig 4**).

Lower the upper unit into position ensuring correct alignment taking care not to damage or dislodge the Premstrip™. In cold weather gentle warming of the Premstrip™ before closing the joint will assist compression. Continue to install the remaining units in a similar manner.

Ensure that the Premstrip™ is compressed to half its thickness in the joint. If necessary add extra weight to the top unit.

When compression is complete trim off and remove any exudation of Premstrip™ from inner surfaces to prevent obstruction.

Units may then be filled or pressure tested to a 5m head of water.

FLEXIBLE JOINTING COMPOUND FOR PRECAST CONCRETE UNITS**(a) MANHOLE JOINTS - continued**

Joints compressed under weight of upper unit (e.g. manhole and house inspection chamber joints).



Fig 3. Apply PremstripTM across the groove and remove the interleaving.

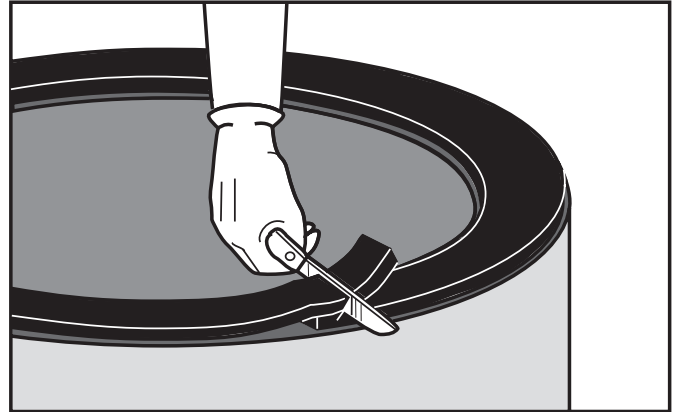

Fig 4. Join Premstrip by tapering the ends 45° with a hot knife.

(b) BOX CULVERTS

Joints using mechanical compression (e.g. pipe and box culvert joints)

Select the recommended size of PremstripTM.

Remove dirt or moisture from the primed surface.

Position the Premstrip as shown in **fig 7 H-I**.

Apply Premstrip by heating the side opposite the interleaving using a gas torch and pressing it onto the primed surface of the sloping face (**fig 5**).

Premstrip must be applied all around the joint with no gaps. Mitre Premstrip into corners of right angle joints (**fig 6**). To join Premstrip, taper the ends by cutting through with a hot knife to provide a 45° bevel, pressing the ends together and smoothing with a hot knife.

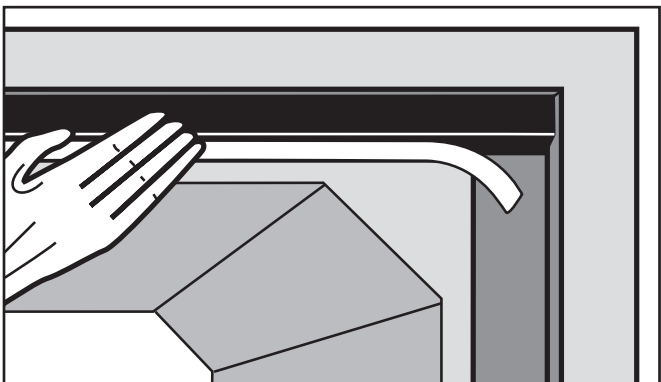

Fig 5. Premstrip is heated on one side and pressed firmly into position.

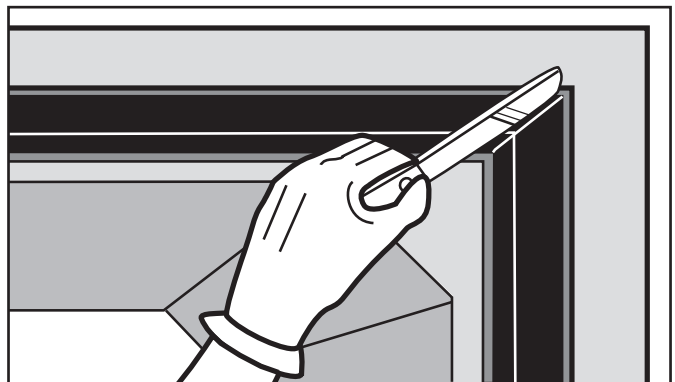

Fig 6. Premstrip should be mitred into corners and right angles.

(b) BOX CULVERTS - continued

Joints using mechanical compression (e.g. pipe and box culvert joints)

Place second unit in position and draw the units together until the Premstrip is compressed. Note: Hardboard placed under the units will ensure correct vertical positioning and avoid scoop-up of gravel into the joint. Use of a crane to support the second unit will assist alignment and minimise the compression forces required.

Pipes and box culverts should be jointed using a hydraulic cable puller or Tirfor with pulleys to ensure that Premstrip is compressed to half its original thickness. A force of approx 1 tonne (10kN) per metre of joint run is required to close the joint in 10-20 minutes at normal temperatures. Maintain the force until the required compression is obtained.

With small diameter pipes it is advisable to partially backfill and tamp down as work progresses to avoid the line snaking as further units are pulled into place.

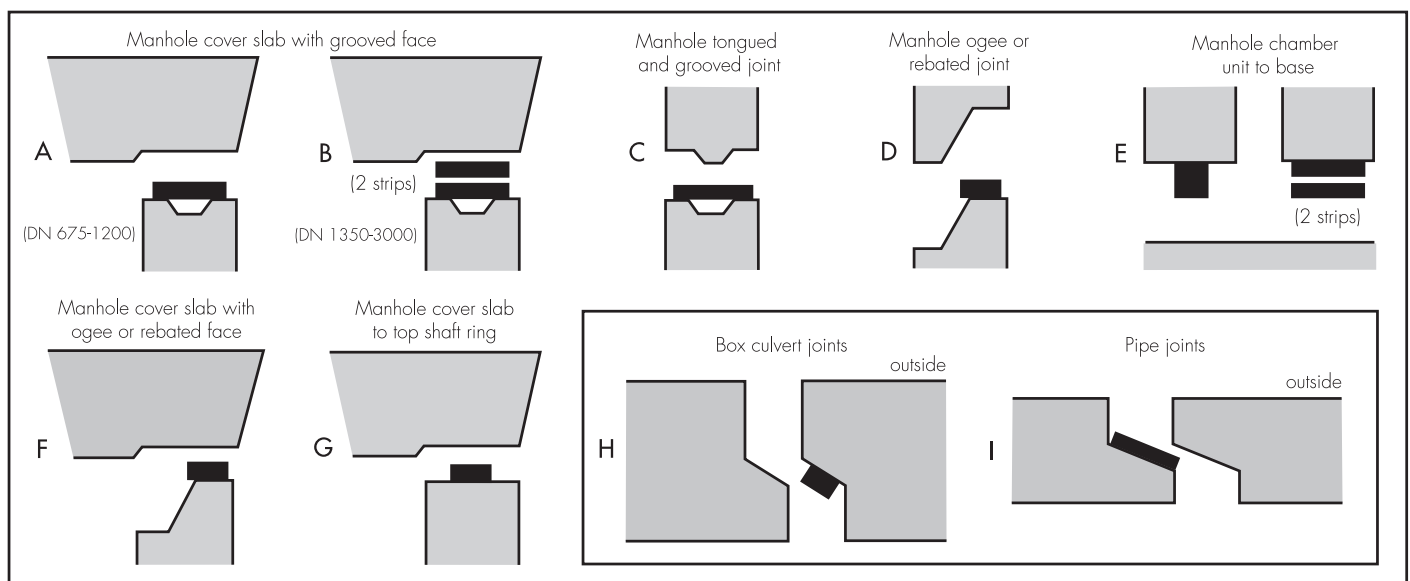

Fig 7. Correct Premstrip position shown in cross section for sealing manhole, box culvert and pipe joints.

GENERAL NOTES

1. Handle concrete units with proper equipment and prevent damage to joint faces.
2. Where there is a risk of over compression the specified joint width can be maintained by positioning hardwood or plywood spacers at intervals around the joint away from Premstrip.
3. Premstrip develops the adhesion required to provide a flexible watertight seal as it is compressed in the joint. Joints should not be made without adequate compression or by caulking.
4. Gentle warming of the Premstrip with a gas torch will assist compression of the joint in cold weather.

FLEXIBLE JOINTING COMPOUND FOR PRECAST CONCRETE UNITS

SAFETY DATA:

HANDLING

- Wear gloves to minimise skin contact and to protect against burns when heating Premstrip™.
- Wash with soap and water.

ACTION IN CASE OF

- **FIRE:** Extinguish with dry powder, carbon dioxide or chemical foam. Air breathing equipment may be necessary in case of a large fire.
- **EYE CONTACT:** Irrigate eyes thoroughly with clean water.
- **SKIN BURNS:** Douse area in cold water. Seek medical advice.
- **INHALLATION:** Remove to fresh air. Seek medical attention if symptoms persist.
- **SWALLOWING:** Seek medical advice.

STORAGE

In cold weather, store Premstrip in a warm place prior to use.

WASTE DISPOSAL

Please minimise or avoid waste wherever possible. Please do not discard waste material, including packaging, in the surrounding environment. Follow all relevant legislation for disposal.

IMPORTANT:

Premier Coatings Ltd pursue a policy to develop and continually improve all of our products and therefore information given in these instructions for use is intended as a general guide and does not constitute a warranty, specification or risk assessment. Instructions for use are intended to provide sufficiently detailed information to achieve successful installation in normal circumstances. These guidelines may not cover all circumstances; however, our sales personnel are committed to assisting the user in establishing the suitability of the product for its intended purpose and additional specific information, advice and training (including Safety Data Sheets) is available. It is strongly recommended that installation is conducted with due regard to Health and Safety using a safe system of work, including risk method statements, in accordance with relevant local statutes and regulations. Equipment used for installation must be suitable for the intended use, maintained in a safe assessments and condition, inspected for signs of deterioration, and used by competent personnel. Any conflict between these guidelines and the specific project specifications must be resolved by the user before work commences. All rights reserved.